

 ozmachine

by  özçelik

# OVERVIEW



Produced and backed by ÖZÇELİK

# ABOUT



**60.000**  
PRODUCTION  
CAPACITY



**43**  
PARTNERS  
WORLDWIDE



**100**  
EXPORT  
COUNTRIES



**40+**  
YEARS  
OF SUCCES

Since 1980, Özçelik Machine Inc. (Özçelik Makina Sanayii ve Ticaret AŞ) has been a pioneer in the manufacturing of aluminum and PVC profile processing machines. Today, we proudly stand as a leading provider of over 70 machines, catering to the diverse needs of our customers.

Our comprehensive range of machines encompasses miter saws, single and double blade saws, crimping machines, corner welding and cleaning machines, notching saws, and more. We are committed to continuous innovation, consistently expanding our product portfolio to include high-value, automated solutions such as CNC processing and cutting centers, aluminum composite panel routers, and iron and steel profile processing equipment.

At Özçelik Machine, we are driven by a passion for technological advancement and an unwavering commitment to quality. Our brand, OZMACHINE, is synonymous with cutting-edge solutions that empower our global clientele to achieve operational excellence and elevate their manufacturing processes.

Partner with Özçelik Machine and experience the transformative power of our technology-driven solutions. Let us guide you towards a future of enhanced productivity, efficiency, and global success.

Özçelik, with its global brand, OZMACHINE, is driven by more than just building machines. We strive to shape the future of profile processing through a set of core values that define who we are and what we stand for.

1. **Customer Centricity:** We believe in building long-lasting relationships with our customers, prioritizing their satisfaction and success in every interaction.

2. **Innovation & Excellence:** We are committed to relentless innovation, pushing the boundaries of technology to deliver cutting-edge, high-quality machines that empower our customers.

3. **Expertise & Reliability:** With over 50 years of experience, we offer unparalleled industry knowledge and expertise, ensuring our machines are reliable and efficient solutions.

4. **Global Vision, Local Touch:** We operate with a global perspective, leveraging a network of dedicated distributors while maintaining a focus on understanding and exceeding the specific needs of each local market.

5. **Sustainability & Responsibility:** We are committed to operating responsibly and sustainably, minimizing our environmental impact, and contributing to the communities we serve.

These values are the foundation of everything we do at OZMACHINE. They guide our decisions, inspire our team, and ultimately shape the future of our company and the industries we serve.

<b>CENTER</b>	<b>4-17</b>	<b>COPY ROUTER</b>	<b>36-37</b>	<b>END MILLING</b>	<b>44-45</b>
ALCOR	4	GALAXY	36	POLAR	44
GARNET	8	STAR	37		
LEPUS	12			<b>ACCESSORIES / COMPLEMENTARY</b>	<b>46-49</b>
SIRIUS	14	<b>CORNER WELDING &amp; CLEANING</b>	<b>38-41</b>	<b>SOLUTION PARTNERS</b>	<b>50</b>
		ORION	38		
<b>CUTTING</b>	<b>18-35</b>	ORBIT	40		
GEMINI	18				
METEOR	22	<b>CORNER CRIMPING</b>	<b>42-43</b>		
LEO	24	APEX	42		
DELTA	26				
SPICA	28				
ORCA	30				
ALFA	32				
VEGA	34				

# ALCOR SERIES

---



**INDUSTRY 4.0  
COMPATIBILITY**

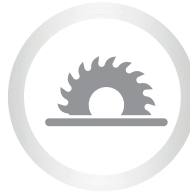

**HIGH SAW MOTOR  
POWER (3KW/4HP)**



**AUTOMATIC CUTTING UNIT WITH INTERMEDIATE  
DEGREE SERVO DRIVE INCLUDED**



**UL CERTIFICATION  
AVAILABLE**



**ERROR-FREE CUTTING CAPABILITY  
WITH AUTOMATIC PROFILE LENGTH  
MEASUREMENT SENSOR**



Automation by  
**FANUC**

We are proud to introduce the ALCOR series, the pinnacle of precision and efficiency in profile cutting and processing for the door and window industry. Specifically designed for PVC and aluminum profile processing, these CNC machines are the cornerstone of innovation for manufacturers seeking superior performance and reliability. At the core of each ALCOR machine lies a robust loading conveyor, ensuring uninterrupted automatic operation to streamline your

production workflow. Engineered with world-leading automation components such as Fanuc controllers and servo motors, our machines offer exceptional precision and consistency, setting new standards for production excellence. Benefiting from the privileges of Industry 4.0, Fanuc controllers offer unmatched advantages in production processes.

# ALCOR SERIES

CENTER



Automation by  
**FANUC**

ALCOR I set the standard for flexibility and speed, delivering swift profile cutting without compromise. For the essential workhorse in PVC and aluminum fabrication, look no further than the ALCOR II R and ALCOR II C models, offering unparalleled precision and efficiency tailored to your requirements.

When increased cutting capacity is essential, the ALCOR IV steps up to the challenge, while the ALCOR V unleashes unlimited flexibility with its five-servo axis and 550mm saw blade, allowing for precise cutting angles like never before. Elevate your fabrication process with the ALCOR series and experience the pinnacle of performance and precision in profile cutting technology.

# ALCOR I

## CNC Profile Cutting Center (5 Servo Axis)

- ◆ Automatic positioning at all degrees between 30° and 150° with servo motion system
- ◆ Pneumatic holder robot with servo axis control and manual adjustment feature for accurate positioning of profiles
- ◆ Industrial PC with Windows based touchscreen and easy to use practical interface and Remote access.
- ◆ Data transfer over remote network connection, Ethernet, and USB
- ◆ Feeding capacity for 10 profiles



# ALCOR II C

## CNC Profile Machining and Cutting Center (8 Servo Axis – 7 Machining Axis for Alu)

- ◆ Automatic positioning at all degrees between 30° and 150° with servo motion system
- ◆ Pneumatic holder robot with servo axis control and manual adjustment feature for accurate positioning of profiles
- ◆ Industrial PC with Windows based touchscreen and easy to use practical interface and Remote access.
- ◆ Feeding capacity for 10 profiles
- ◆ Automatic lubrication in processing area.



# ALCOR II R

## CNC Profile Machining and Cutting Center (8 Servo Axis - 14 Machining Axis for PVC)

- ◆ Automatic positioning at all degrees between 30° and 150° with servo motion system
- ◆ Pneumatic holder robot with servo axis control and manual adjustment feature for accurate positioning of profiles
- ◆ Industrial PC with Windows based touchscreen and easy to use practical interface and Remote access
- ◆ Feeding capacity for 10 profiles
- ◆ Ability to process 4 different surfaces of a profile



# ALCOR IV

## CNC Profile Machining and Cutting Center (11 Servo Axis)

- ◆ Automatic gripper with servo axis control
- ◆ Automatic positioning at all degrees between 0° and 360° with servo motion system
- ◆ Pneumatic holder robot with servo axis control and manual adjustment feature for accurate positioning of profiles
- ◆ Windows based industrial PC
- ◆ User-friendly HMI and Remote Access
- ◆ Feeding capacity for 4 profiles
- ◆ Ability to process 4 different surfaces of a profile

# ALCOR V

## CNC Profile Machining and Cutting Center / with Full Notching Capability (12 Servo Axis)

- ◆ Servo controlled rotation axis
- ◆ Automatic positioning at all degrees between 0° and 360° with servo motion system
- ◆ Automatic positioning at between 0° and 180° degrees with the 5th axis
- ◆ Pneumatic holder robot with servo axis control and manual adjustment feature for accurate positioning of profiles
- ◆ Feeding capacity for 4 profiles
- ◆ Automatic lubrication in processing area

# GARNET SERIES

---

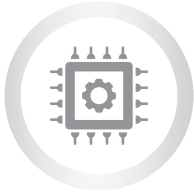

**SIMULTANEOUS  
PROCESSING  
CAPABILITY**



**DRILLING, CUTTING, AND MILLING  
CAPABILITY ON PROFILES**

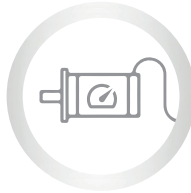

**SERVO-CONTROLLED  
VISE POSITIONING  
(SPEED)**

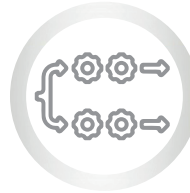

**4-STATION PROCESSING  
CAPABILITY**

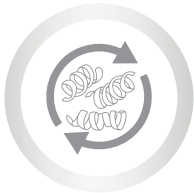

**AUTOMATIC CHIP  
EVACUATION**



**UL CERTIFICATION  
AVAILABLE**





Introducing the GARNET series, the epitome of precision and efficiency in profile processing CNC machines tailored to cover the needs of the industry. Specifically crafted for aluminum, light alloy and even some steel profile processing, these machines are the ultimate solution for manufacturers seeking unparalleled performance and reliability.

At the core of every GARNET machine lies precision processing capability, ensuring meticulous execution of every task. Engineered with world-leading automation components such as Fanuc controllers and servo motors, our machines deliver exceptional precision and consistency, setting new benchmarks in production excellence. Leveraging the advantages of Industry 4.0, our Fanuc controllers offer unmatched benefits, revolutionizing production processes.

# GARNET SERIES

CENTER



Automation by  
**FANUC**

GARNET series offers a range of options to suit diverse needs. From the versatile GARNET Mini capable of performing milling, drain channel opening, drilling, marking, and milling processes on aluminum and PVC profiles, to the compact and efficient GARNET XS4 designed for specific drilling and milling operations, on 4 axis, to our most sophisticated model, the GARNET 5X each machine is equipped with cutting-edge features including automatic tool replacement, precision processing at any

angle, automatic magazine for tools, automatic clamping positioning, touchscreen interface, remote access, and high processing capacity for increased efficiency. Elevate your fabrication processes with the GARNET series and experience a new era of precision and productivity.

# GARNET 5X

## CNC Profile Machining Center (5 Axis)

Used for performing milling, drain channel opening, drilling, marking and milling processes on aluminum and PVC profiles

- ◆ Precise process at any angle between -90° and +90°
- ◆ Precise process at 0°/180° in axis A and 0°/360° in axis C
- ◆ Automatic tool replacement, Automatic magazine for 20+1 tools
- ◆ Fully automatic clamping positioning
- ◆ Touchscreen and Remote access
- ◆ Automatic lubrication in processing area
- ◆ Ability to process light steel profiles up to 5 mm thickness



# GARNET 8000

## CNC Profile Machining Center (4 Axis)

Used for performing milling, drain channel opening, drilling, marking and milling processes on aluminum and PVC profiles

- ◆ Precise process at any angle between -90° and +90°
- ◆ Automatic tool replacement
- ◆ Automatic magazine for 20+1 tools
- ◆ Automatic clamping positioning
- ◆ Touchscreen and Remote access
- ◆ Automatic lubrication in processing area
- ◆ Ability to process light steel profiles up to 5 mm thickness



# GARNET XS

## CNC Profile Machining Center (3+1 Axis)

Used for performing milling, drain channel opening, drilling, marking and milling processes on aluminum and PVC profiles

- ◆ Ability to process at fixed angles of -90, 0 and +90°
- ◆ Automatic tool replacement
- ◆ Automatic magazine for 8 tools
- ◆ Automatic clamping positioning
- ◆ Touchscreen and Remote access
- ◆ Data transfer over remote network connection, Ethernet/USB
- ◆ Processing up to 6000 mm meters with 2 stoppers



# GARNET XS4

## CNC Profile Machining Center (4 Axis)

Used for performing milling, drain channel opening, drilling, marking and milling processes on aluminum and PVC profiles

- ◆ Precise process at any angle between -90° and +90°
- ◆ Ability to process light steel profiles up to 5 mm thickness
- ◆ Automatic tool replacement, Automatic magazine for 8 tools
- ◆ Automatic clamping positioning
- ◆ Industrial PC with Windows based touchscreen and easy to use practical interface and Remote access
- ◆ Data transfer over remote network connection, Ethernet/USB



# GARNET Mini

## 3 Axis NC Compact Processing Center with Copy Router Function

Garnet Mini is a compact machining center with parametric program templates developed to perform various drilling and milling operations on Aluminum and pvc profiles

- ◆ 10" HMI Touchscreen
- ◆ Easy to program user interface
- ◆ Easy profile positioning with gauge and laser marking
- ◆ Spindle motors run independently on 3 different surfaces



# LEPUS SERIES

CENTER



Step into a new era of precision and efficiency with the LEPUS series of CNC-controlled aluminum composite panel processing and cutting machines. Crafted specifically for the demanding needs of aluminum composite panel fabrication, each machine in the LEPUS series is engineered to deliver unparalleled performance and reliability.

At the heart of the LEPUS series lies cutting-edge technology, featuring DELTA controllers and servo motors renowned for their world-leading precision and automation capabilities. Whether you're tackling v-channel opening, processing, or sizing operations, the LEPUS series ensures swift and precise results every time.



POWERFUL VACUUM TABLE



7.5 KW  
AUTOMATIC  
TOOL-  
CHANGING  
SPINDLE



HIGH-RIGIDITY  
POLYETHYLENE TABLE



INDIVIDUALLY  
CONTROLLABLE  
(5) VACUUM  
ZONES



POWERFUL DUST  
EXTRACTION SYSTEM



UL  
CERTIFICATION  
AVAILABLE



## LEPUS X

### CNC ACP Router (3 Axis, Tool Magazine) - 4 m / 7 m

Used for v-channel opening, processing, and sizing operations of aluminum and composite panels and plates

- ◆ Automatic magazine for 5 tools
- ◆ Smart CAM post processing
- ◆ Vacuuming in independent sections
- ◆ Automatic tool length measurement
- ◆ External dust vacuuming system
- ◆ Automatic, pneumatic alignment system
- ◆ Vacuum pump power 2 x7,5 Kw
- ◆ Spindle motor power 7,5 kW

## LEPUS II

### CNC ACP Router (3 Axis, 4 Spindles) - 4 m / 7 m

Used for v-channel opening, processing, and sizing operations of aluminum and composite panels and plates, can be processed with optional equipment

- ◆ Composite plate fixing and superior processing quality with strong vacuum.
- ◆ Tool replacement magazine: capacity for 4 independently operating fan cooled spindle motors
- ◆ Ability to process wooden and plastic plates by replacement of milling cutter.
- ◆ Automatic milling cutter length reset
- ◆ External dust vacuuming system
- ◆ Automatic, pneumatic alignment system
- ◆ Data transfer over remote network connection, Ethernet, and USB and Remote access
- ◆ Vacuum motor power 2,75 kW
- ◆ Spindle motor power 4x3 kW



YouTube

# SIRIUS SERIES

---



**PRECISE WELDING**  
WITH THE MOLD SYSTEM WELDING



**SAFETY**  
PROTECTION CABIN



**EFFICIENCY**  
UP TO 350° C WELD CAPABILITY



**DURABILITY**  
THANKS TO ITS EXTREMELY RIGID CHASSIS



**USER FRIEND**  
EASY TO USE WITH THE BUTTON SYSTEM



SIRIUS which is the line of Automatic PVC welding and edge cleaning has been developed for cleaning processes occurring in profile after welding and welding at the same time of four edges of plastic profiles. With automatic frame unloading unit,

fast transfer to cleaning unit of profile with robot system and with the system of automatic profile rotating, SIRIUS gains time substantially while decreasing workload on user in welding and cleaning processes.

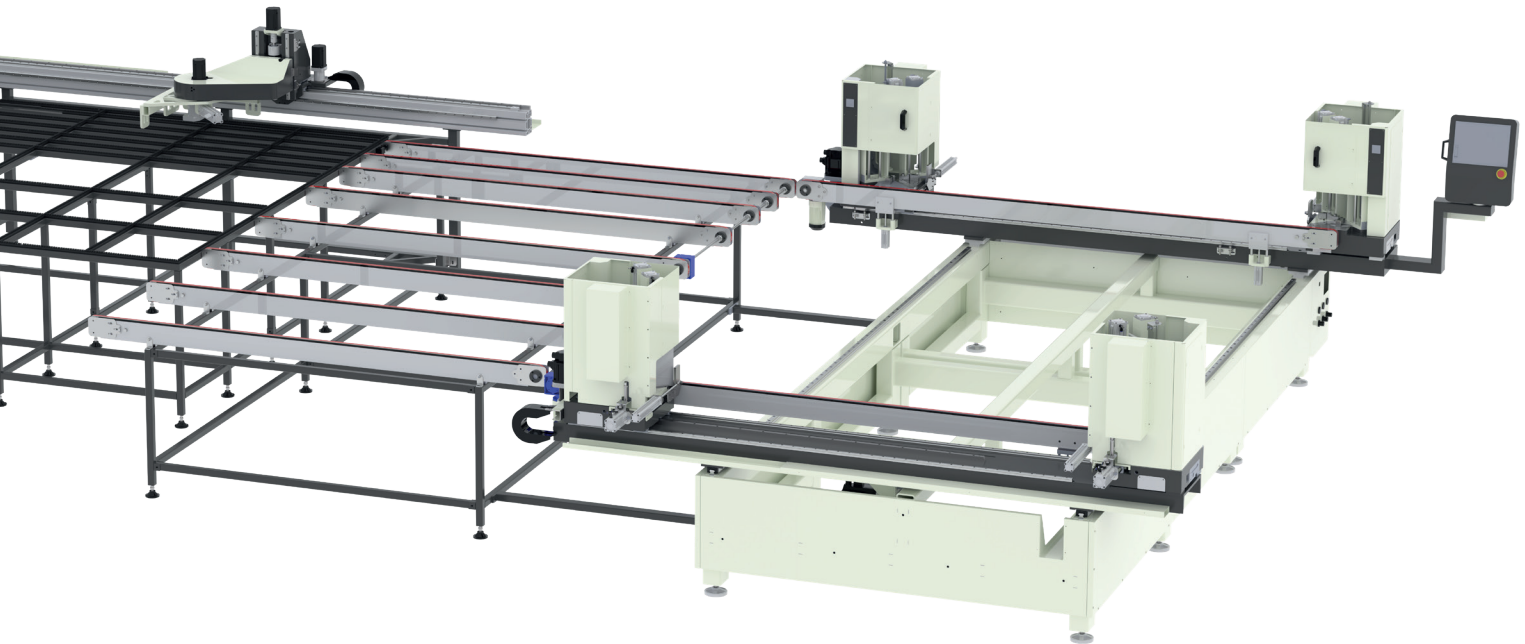

# SIRIUS SERIES

CENTER

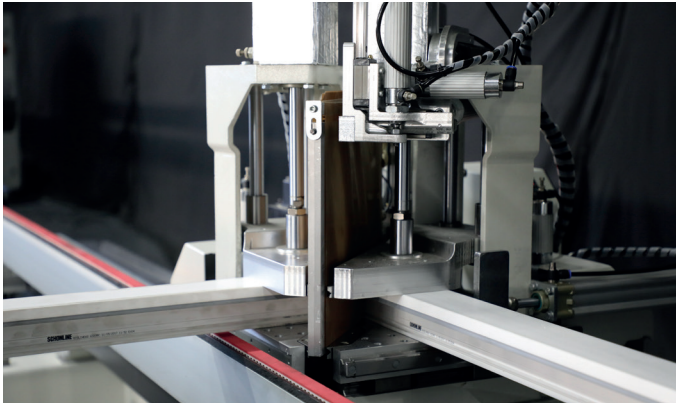

Through its electronic thermostat heat adjustment between 0°C - 350°C, welding time adjustment and digital controlled heat, quadruple welding unit provides scattering homogenised to plaque of heat.

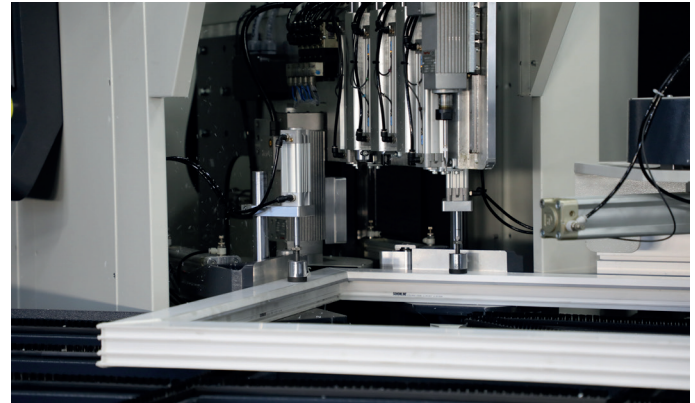

11 pieces of profile cleaning blade and two independent cleaning unit, cleaning bottom, top, interior and external surfaces of the profile.





# SIRIUS

## Automatic PVC Welding and Cleaning Line

Used for simultaneously welding four corners of PVC profiles and removing the burrs from the profiles after welding.

- ◆ Pneumatic motion
- ◆ Automatic frame output unit and automatic profile rotation system
- ◆ Batch processing and precision measurement.
- ◆ Process programming and large memory.
- ◆ Safe working area with safety barrier
- ◆ Welding time adjustment and digitally controlled heating
- ◆ Heat adjustment up to 350°C with digital thermostat.
- ◆ 0.2 mm welding range
- ◆ Touchscreen control panel and profile recognition system
- ◆ Quick transferring the profile to cleaning unit with robot system after welding.
- ◆ Cleaning of bottom, top, internal and external surfaces of the profile by two independent cleaning units
- ◆ Easy programming with manual control system (hand wheel)
- ◆ Manual operator adjusted axial speeds.
- ◆ Real time communication between two machines
- ◆ Memory capacity for 1000 profiles
- ◆ Manual and automatic operation
- ◆ Automatic cleaning with 11 profile cleaning blades
- ◆ Separate cleaning blades for colored and white profiles
- ◆ Data transfer over remote network connection, Ethernet and USB
- ◆ Alarm and warning sign on screen.
- ◆ Quick and easy to replace hot press Teflon
- ◆ Processing time monitoring on screens during operation
- ◆ Uniform heat distribution on plate, profile cooling station
- ◆ Rotation speed optimization and picking up unit for finished profile on the line



 YouTube

# GEMINI SERIES

---



**INDUSTRY 4.0  
COMPATIBILITY**



**MOBILE PROFILE  
SUPPORT UNITS**



**SLICING  
CAPABILITY**

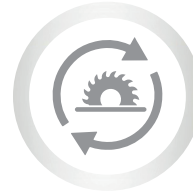

**AUTOMATIC SAW BLADE  
EXITS ADJUSTMENT**



**UL CERTIFICATION  
AVAILABLE**



**FANUC AUTOMATION AVAILABLE**  
(GEMINI V R MODEL ONLY)

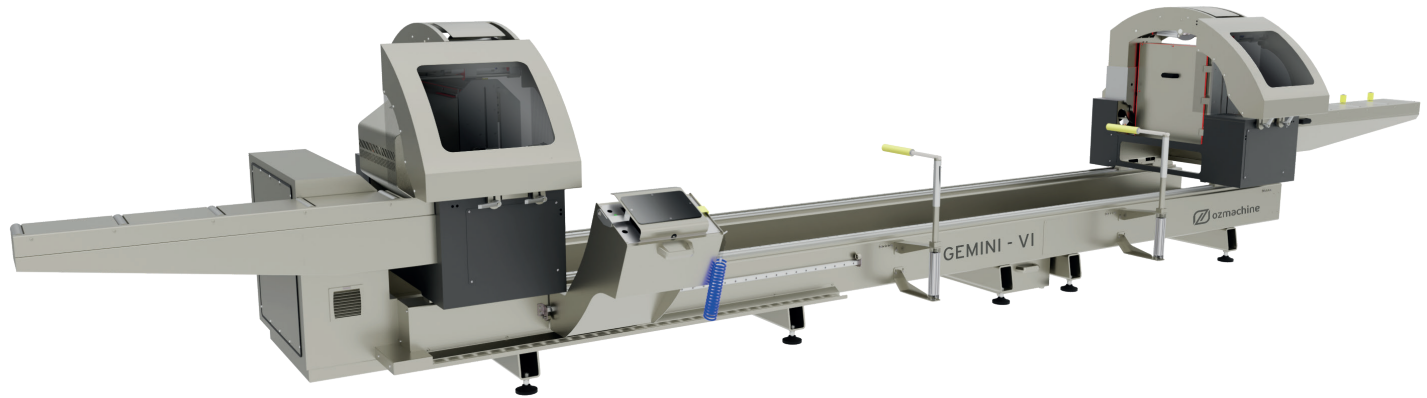

Automation by  
**FANUC**

The specific properties and advantages of each Machine are as follows: All machines in the GEMINI series are quick and solutional. They are supplied with LS controllers, Servo motors and automation which are world leading automation components. Engineered with world-leading automation components such as Fanuc controllers and servo motors, our machines offer exceptional precision and consistency, setting new standards for production excellence. Benefiting from

the privileges of Industry 4.0, Fanuc controllers offer unmatched advantages in production processes. The perfect choice when flexible and fast cutting of profiles is required without any processing.

# GEMINI SERIES

## CUTTING



Whether it's aluminum, pvc profiles, the GEMINI Series delivers swift, seamless cutting solutions with uncompromising quality.

Meet your production demands head-on with our range of GEMINI machines, including the versatile GEMINI II A, the robust GEMINI IV M, and the precision engineered GEMINI V R. Designed to excel in PVC and aluminum door and window fabrication, each model in the series is meticulously crafted to streamline your workflow and elevate your craftsmanship.

Experience unlimited flexibility with the GEMINI Series. With its 400-450-550-600 mm saw blade, GEMINI offers unmatched cutting capacity and versatility, allowing you to tackle any project with ease. Elevate your cutting experience with the GEMINI Series and discover a new standard of precision and efficiency in profile cutting.

## GEMINI II A

Used for cutting processes of aluminum, pvc profiles

- ◆ Electronically controlled X axis
- ◆ Positioning control with magnetic ruler
- ◆ Cutting at any desired angle between -45° and +45°
- ◆ 0°, 15°, 22.5°, 30°, 45° right and left angle fixing.
- ◆ Adjustable saw blade travel speed
- ◆ Ability to save recipes
- ◆ Intermediate profile support



## GEMINI IV M

Used for cutting processes of aluminum, pvc profiles

- ◆ Manually controlled X axis
- ◆ Secure cutting by the cover equipped with a safety sensor
- ◆ Rapid angle positioning of heads hydro-pneumatically at angles 45° and 90°, manual positioning at intermediate angles
- ◆ Button Controlled
- ◆ Intermediate profile support

## GEMINI IV SA

Used for cutting processes of aluminum, pvc profiles

- ◆ Hydro-Pneumatic cutting
- ◆ Electronically controlled X axis
- ◆ Rapid angle positioning of heads hydro-pneumatically at angles -22,5°, -45° and 90°, manual positioning at intermediate angles
- ◆ Industrial PC with Windows based touchscreen and easy to use practical interface and Remote access
- ◆ Intermediate profile support



## GEMINI V R

Used for cutting processes of aluminum, pvc profiles

- ◆ Servo controlled rotation axis
- ◆ Automatic positioning at all degrees between -22.5° and +45° with servo motion system
- ◆ Industrial PC with Windows based touchscreen and easy to use practical interface and Remote access
- ◆ Process programming and large memory
- ◆ Intermediate profile support



## GEMINI V SA

Used for cutting processes of aluminum, pvc profiles

- ◆ Hydro-pneumatic cutting
- ◆ Electronically controlled X axis
- ◆ Secure cutting by the cover equipped with a safety sensor
- ◆ Rapid angle positioning of heads hydro-pneumatically at angles -22,5°, -45° and 90°, manual positioning at intermediate angles
- ◆ Intermediate profile support



## GEMINI VI

Used for cutting processes of aluminum, pvc profiles

- ◆ Servo controlled rotation axis
- ◆ Automatic positioning at all degrees between -22.5° and +45° with servo motion system
- ◆ Industrial PC with Windows based touchscreen and easy to use practical interface and Remote access
- ◆ Process programming and large memory
- ◆ Intermediate profile support

## GEMINI X

Used for cutting processes of aluminum, pvc profiles

- ◆ Servo controlled rotation axis
- ◆ Automatic positioning at all degrees between 30° and 90° with servo motion system
- ◆ Industrial PC with Windows based touchscreen and easy to use practical interface and Remote access
- ◆ Data transfer over remote network connection, Ethernet/USB
- ◆ Intermediate profile support



# METEOR SERIES

## CUTTING



The METEOR family of single head rising blade saws, handles aluminum, pvc, and wood profiles with its efficient hydro-pneumatic cutting system. The adjustable speed ensures optimal performance for each material, while the wide-angle range (-67.5° to +67.5°) and pre-set fixed angles offer unmatched precision and flexibility. Maximize your cutting capacity with the mobile miter and prioritize safety with the secure cutting feature and integrated safety sensor. 4 standard Pneumatic clamps deliver a firm grip on your workpieces, guaranteeing accurate and worry-free cuts every time.



### DURABILITY

THANKS TO ITS EXTREMELY RIGID CHASSIS



### HIGH CAPACITY

INCREASE IN CUTTING CAPACITY WITH MOBILE MITER



### SAFETY

PROTECTION CABIN



### PRECISE CUTTING

4 STANDARD CLAMPS



## METEOR 600

**Automatic Rising Blade Saw Ø 600 mm with 3 m Roller Conveyor**

Used for cutting processes of aluminum, pvc, and wooden profiles

- ◆ Hydro-Pneumatic cutting process
- ◆ Secure cutting by the cover equipped with a safety sensor
- ◆ Cutting speed adjustment based on the profile
- ◆ Cutting at any desired angle between -67.5° and 67.5°
- ◆ Cutting at -67.5°, -45°, -30°, -22.5°, -15°, 0°, 15°, 22.5°, 30°, 45°, 67.5°, right and left fixed angles
- ◆ Increase in cutting capacity with mobile miters
- ◆ Pneumatic vertical and horizontal clamps



## METEOR 500

**Automatic Rising Blade Saw Ø 500 mm with 3 m Roller Conveyor**

Used for cutting processes of aluminum, pvc, and wooden profiles

- ◆ Hydro-Pneumatic cutting process
- ◆ Secure cutting by the cover equipped with a safety sensor
- ◆ Cutting speed adjustment based on the profile.
- ◆ Cutting at any desired angle between -67.5° and 67.5°
- ◆ Cutting at -67.5°, -45°, -30°, -22.5°, -15°, 0°, 15°, 22.5°, 30°, 45°, 67.5° right and left fixed angles
- ◆ Increase in cutting capacity with mobile miters
- ◆ Pneumatic vertical and horizontal clamps



## METEOR 420

**Automatic Rising Blade Saw Ø 420 mm with 3 m Roller Conveyor**

Used for cutting processes of aluminum, pvc, and wooden profiles

- ◆ Hydro-Pneumatic cutting process
- ◆ Secure cutting by the cover equipped with a safety sensor
- ◆ Cutting speed adjustment based on the profile
- ◆ Cutting at any desired angle between -67.5° and 67.5°
- ◆ Cutting at -67.5°, -45°, -30°, -22.5°, -15°, 0°, 15°, 22.5°, 30°, 45°, 67.5° right and left fixed angles
- ◆ Increase in cutting capacity with mobile miters
- ◆ Pneumatic vertical and horizontal clamps



# LEO SERIES

## CUTTING



The LEO family of single head front blade saws tackles aluminum, pvc profiles with effortless ease, thanks to its powerful hydro-pneumatic cutting and servo-controlled rotation axis. Prioritize safety with the secure cutting cover and safety sensor, while enjoying automatic positioning from -22,5° to +45° via the intuitive servo motion system.

Boost your efficiency with an industrial PC featuring a Windows touchscreen and remote access capabilities. Data transfer is seamless via Ethernet or USB, enabling batch processing and precision cutting. Automate your workflows by importing cutting lists or programming processes in the large memory. Double-hand control ensures operator safety, while adjustable blade speed and travel distance provide granular control.



### CONTINUES ACCURATE AND FAST CUTTING

EQUIPPED WITH THE SERVO GRIPPER (ONLY LEO PLUS MODEL)



### PRECISE MEASUREMENT

SERVO CONTROLLED AXIS



### SAFETY

PROTECTION CABIN



### HIGH CAPACITY

WITH THE 550 Ø MM SAW



# LEO X

## Automatic Radial Saw Ø 550 mm - 2 Axis Servo Controlled

Used for cutting processes of aluminum, pvc, and wooden profiles.

- ◆ Hydro-Pneumatic cutting
- ◆ Servo controlled rotation axis
- ◆ Secure cutting by the cover equipped with a safety sensor
- ◆ Automatic positioning at all degrees between 30° and 90° with servo motion system
- ◆ Industrial PC with Windows based touchscreen and easy to use practical interface
- ◆ Data transfer over remote network connection, Ethernet, and USB
- ◆ Batch processing and precision cutting
- ◆ Ability to perform cutting automatically from the list or manually
- ◆ Process programming and large memory
- ◆ Double hand control application
- ◆ Adjustable saw blade travel speed
- ◆ Ability to control saw blade travel distance
- ◆ Automatic horizontal and vertical clamps
- ◆ Automatic size calculation for mold cutting
- ◆ Resume cutting feature (emergency stops, blackouts, etc.) provides cutting advice by making a full scan in cutting list and detecting uncut pieces
- ◆ Ability to send bar code information of different profile batches by profile list input without using a cutting optimization program and ability to choose profile from the list in batch cutting



# LEO R

## Automatic Front Blade Saw Ø500 / Ø600 mm - 2 Axis Servo Controlled

Used for cutting processes of aluminum, pvc, and wooden profiles

- ◆ Hydro-Pneumatic cutting
- ◆ Servo controlled rotation axis
- ◆ Secure cutting by the cover equipped with a safety sensor.
- ◆ Automatic positioning at all degrees between -22.5° and +45° with servo motion system
- ◆ Industrial PC with Windows based touchscreen and easy to use practical interface
- ◆ Data transfer over remote network connection, Ethernet, and USB
- ◆ Batch processing and precision cutting
- ◆ Ability to perform cutting automatically from the list or manually
- ◆ Adjustable saw blade travel speed
- ◆ Ability to control saw blade travel distance
- ◆ Process programming and large memory
- ◆ Automatic horizontal and vertical clamps
- ◆ Automatic size calculation for mold cutting
- ◆ Double hand control application



# LEO PLUS

## Automatic Cutting Machine Ø 550 mm with Robot Profile Drive System and 2 Axis Servo Control

Used for cutting processes of aluminum, pvc, and wooden profiles

- ◆ Hydro-Pneumatic cutting
- ◆ Servo controlled rotation axis
- ◆ Servo controlled gripper
- ◆ Secure cutting by the cover equipped with a safety sensor
- ◆ Automatic positioning at all degrees between -22,5° and +45° with servo motion system
- ◆ Industrial PC with Windows based touchscreen and easy to use practical interface
- ◆ Data transfer over remote network connection, Ethernet, and USB
- ◆ Batch processing and precision cutting
- ◆ Ability to perform cutting automatically from the list or manually
- ◆ Process programming and large memory
- ◆ Double hand control application
- ◆ Adjustable saw blade travel speed
- ◆ Ability to control saw blade travel distance
- ◆ Automatic horizontal and vertical clamps
- ◆ Automatic size calculation for mold cutting
- ◆ Resume cutting feature (emergency stops, blackouts, etc.) provides cutting advice by making a full scan in cutting list and detecting uncut pieces
- ◆ Ability to send bar code information of different profile batches by profile list input without using a cutting optimization program and ability to choose profile from the list in batch cutting



# DELTA SERIES

## CUTTING



The DELTA family of single head rising blades, effortlessly slice and automatic cut aluminum, pvc, and wood profiles with this robust machine. Its wide Ø 500 mm saw blade handles even hefty profiles, while servo-driven automatic feeding ensures efficient batch slicing. Secure cutting is prioritized with the cover and safety sensor, while the automatic clamping system and digital travel distance adjustment guarantee precise results. Streamline workflows with the intuitive touchscreen control panel, process programming, and large memory for complex cuts.



### CONTINUES ACCURATE AND FAST CUTTING

SERVO CONTROLLED PROFILE SLIDING



### SAFETY

PROTECTION CABIN



### PRECISE MEASUREMENT

STANDARD CLAMPS



### ACCURATE DRILLING

WITH THE SERVO CONTROL SYSTEM 2,2 KW SPINDLE MOTOR



## DELTA D

### Automatic Profile Slicing Machine with Rising Blade Ø 500 mm with Drilling Option

Used for slicing and flat cutting processes of aluminum, pvc, and wooden profiles

- ◆ Used for slicing and flat cutting processes of aluminum, PVC and wooden profiles
- ◆ Wide profile cutting with Ø 500 mm saw blade
- ◆ Servo driven automatic profile feeding and batch slicing process
- ◆ Automatic clamping system
- ◆ Cutting speed adjustment
- ◆ Secure cutting by the cover equipped with a safety sensor
- ◆ Touchscreen control panel
- ◆ Process programming and large memory
- ◆ Additional Drilling option

## DELTA

### Automatic Profile Slicing Machine with Rising Blade Ø 500 mm with Drilling Option

Used for slicing and flat cutting processes of aluminum, pvc, and wooden profiles

- ◆ Used for slicing and flat cutting processes of aluminum, PVC and wooden profiles
- ◆ Wide profile cutting with Ø 500 mm saw blade
- ◆ Servo driven automatic profile feeding and batch slicing process
- ◆ Automatic clamping system
- ◆ Cutting speed adjustment
- ◆ Secure cutting by the cover equipped with a safety sensor.
- ◆ Touchscreen control panel
- ◆ Process programming and large memory

# SPICA SERIES

## CUTTING



**HIGH CAPACITY**  
WITH THE 550 Ø MM SAW



**SAFETY**  
PROTECTION CABIN



**FLEXIBLE WORKING**  
90°/180° MOVABLE CONVEYOR



**DURABILITY**  
THANKS TO ITS EXTREMELY  
RIGID CHASSIS

The SPICA family of single head saws empowers you to achieve intricate V cuts, arrow cuts, and clean 90° end notches on both aluminum and PVC profiles, all while minimizing material waste. Its versatility extends beyond standard applications, tackling diverse notching needs for sash, frame, mullion, and transom combinations commonly found in curtain walls, winter gardens, skylights, and even unique design projects requiring specific angles.



## SPICA F

### Facade Notching Machine

- ◆ SPICA F notching saw is a proven machine for aluminum construction
- ◆ A wide variety of notches can be made at the end of the profile bar using two saw units arranged independently of one another
- ◆ Both saw blades can be swiveled within a range of  $\pm 65^\circ$  using a worm gear with a hand crank
- ◆ The material support table can be adjusted both in height and depth using column guides
- ◆ The notching saw type SPICA F is the universal machine for facade and winter garden construction
- ◆ Precise ball bushing guidance of the tool slide on hardened and ground steel shafts

## SPICA

### V Cut & 90° Notching Machine

- ◆ Hydro-Pneumatic cutting process
- ◆ Adjustable saw blade travel speed to the profiles
- ◆ Double hand start

# ORCA SERIES

## CUTTING



### DURABILITY

THANKS TO ITS EXTREMELY RIGID CHASSIS



### SAFETY

PROTECTION CABIN



### PRECISE MEASUREMENT

WITH THE MOLD SYSTEM CUTTING



### COMPACT

THANKS TO ITS SMALL  
EXTREMELY RIGID CHASSIS

The ORCA family of rising blade saws tackles vinyl window strip cutting at a precise 45° angle with effortless ease. The pneumatic cutting system ensures clean and efficient cuts, while the automatic return to the starting point minimizes downtime. A conveyor system equipped with measuring equipment ensures accuracy and consistency in every cut. For added control, adjust both the cutting and conveying speeds based on your specific needs.



COMET DD pictured above

## ORCA

### Automatic Saw for PVC Strips / Aviable Digital Conveyor

Used for cutting window strips of pvc profiles at an angle of 45°

- ◆ Pneumatic cutting
- ◆ Automatic returning to process starting point
- ◆ Conveyor system with measuring equipment

## ORCA DD

### Automatic Saw for PVC Strips / Aviable Digital Conveyor

Used for cutting window strips of pvc profiles at an angle of 45°

- ◆ Pneumatic cutting
- ◆ Automatic returning to process starting point
- ◆ Conveyor system with measuring equipment

# ALFA SERIES

## CUTTING



The ALFA family of portable powerful saw tackles a wide range of cutting tasks with its Ø 300 mm blade and comprehensive angle capabilities. Achieve any desired angle between -45° and +45°, including pre-set options like 0°, 5°, 10°, 15°, 20°, 22.5°, 25°, 30°, 35°, 40°, and 45° for both right and left angles.

For even greater flexibility, the head tilts left between 0° and 45°, enabling efficient angled cuts. A laser guide ensures impeccable accuracy, while screw workpiece clamps and a length stop kit provide secure holds for different material sizes.



### DURABILITY

THANKS TO ITS EXTREMELY RIGID CHASSIS



### SAFETY

PROTECTION CABIN



### USER FRIEND

EASY AND SAFETY USE



### HIGH CAPACITY

WITH THE 300 Ø MM SAW





## ALFA S

### Portable Cutting Machine Ø 300 mm

Used for cutting processes of aluminum, pvc, and wooden profiles

- ◆ Safe cutting with double spring system and saw barrier
- ◆ 0°, 15°, 22.5°, 30°, 45° right and left angle fixing
- ◆ Cutting at any desired angle between -45° and +45°

## ALFA X

### Portable Compound Radial Saw with Tabletop Ø 300 mm

Used for cutting processes of aluminum, pvc, and wooden materials

- ◆ Cutting at any desired angle between -45° and +45°
- ◆ 0°, 5°, 10°, 15°, 20°, 22.5°, 25°, 30°/35°, 40°, 45° right and left angle fixing
- ◆ Head with ability to tilt left between 0° and 45° (Performs tilt cutting when lower plate is at 0 (Zero) position)
- ◆ Additional Laser Guide for accurate cuts
- ◆ Screw workpiece clamp
- ◆ Length stop kit for wide material support

## ALFA

### Portable Compound Saw with Tabletop Ø 300 mm

Used for cutting processes of aluminum, pvc, and wooden profiles

- ◆ Safe cutting with double spring system and saw barrier
- ◆ 0°, 15°, 22.5°, 30°, 45° right and left angle fixing
- ◆ Cutting at any desired angle between -45° and +45°



## NEW ALFA

### Portable Compound saw with Tabletop Ø 300 mm

Used for cutting processes of aluminum, pvc, and wooden materials

- ◆ Safe cutting with double spring system and saw barrier
- ◆ Ability to cut on the upper table
- ◆ Cutting at any desired angle between -45° and +45°
- ◆ Head with ability to tilt left between 0° and 45° (Performs tilt cutting when lower plate is at 0 (Zero) position)
- ◆ 0°, 15°, 22.5°, 30°, 45° right and left angle fixing

# VEGA SERIES

# CUTTING



The VEGA family of single head saws deliver smooth and precise cuts with its hydro-pneumatic cutting system. Its safety features are top-notch, featuring a double spring system and saw barrier for operator protection. Pneumatic vertical and horizontal clamps ensure your profiles are securely held during cutting, while the cast core adds impact resistance for durability.

Experience ultimate versatility with cutting speed adjustments to match your profile needs and the ability to tackle any angle between -45° and +45°.



**EFFICIENCY**  
AUTOMATIC SYSTEM (ONLY VEGA II MODEL)



**SAFETY**  
SAW PROTECTION



**DURABILITY**  
THANKS TO ITS EXTREMELY RIGID CHASSIS



**PRECISE MEASUREMENT**  
2 STANDARD CLAMPS



## VEGA II

### Automatic Cutting Machine Ø 400 mm

- ◆ Hydro-Pneumatic cutting process
- ◆ Safe cutting with double spring system and saw barrier
- ◆ Pneumatic vertical and horizontal clamps
- ◆ Cast core with impact resistance
- ◆ Double hand control application
- ◆ Cutting speed adjustment based on the profile
- ◆ Cutting at any desired angle between -45° and +45°
- ◆ 0°, 15°, 22,5°, 30°, 45° right and left angle fixing



 YouTube

## VEGA II M

### Manual Cutting Machine - Pneumatic Clamps Ø 400 mm

- ◆ Manual cutting process and operating system
- ◆ Safe cutting with double spring system and saw barrier
- ◆ Pneumatic vertical and horizontal clamps
- ◆ Cast core with impact resistance
- ◆ Cutting at any desired angle between -45° and +45°
- ◆ 0°, 15°, 22,5°, 30°, 45° right and left angle fixing



 YouTube

# GALAXY SERIES

## COPY ROUTER



**PRECISE PROCESSING**  
WITH THE 1,1-KW SPINDLE MOTORS



**DURABILITY**  
THANKS TO ITS EXTREMELY RIGID CHASSIS



**SAFETY**  
PROTECTION CABIN



**FAST PROCESSING**  
HIGH FREQUENCY SPINDLE MOTORS

The GALAXY family of single head copy routers empower you to create precise slots and channels for locks, handles, hinges, and latches on aluminum and vinyl profiles, without the need for profile rotation. Its advanced copy mechanism ensures consistent results, while profile gauges enable independent opening of various channels, offering unmatched flexibility.

# GALAXY I

## Copy Router Machine

Used for cutting appropriate slots on aluminum and pvc profiles for mounting locks, grips, hinges, latches, and opening channels

- ◆ Copy assembly matching the process
- ◆ Ability to open various channels independently of the copy assembly with profile gauges
- ◆ Pneumatic clamps



# GALAXY III

## Copy Router Machine with Triple Slot Drilling and Water Discharge

Used for cutting appropriate slots on aluminum and pvc profiles for mounting locks, grips, hinges, latches, and opening channels

- ◆ Copy assembly matching the process
- ◆ Ability to open various channels independently of the copy assembly with profile gauges
- ◆ Pneumatic clamps
- ◆ Triple grip slot drilling system



# GALAXY I P

## Portable Copy Router Machine

Used for cutting appropriate slots on aluminum and pvc profiles for mounting locks, grips, hinges, latches, and opening channels

- ◆ Copy assembly matching the process
- ◆ Ability to open various channels independently of the copy assembly with profile gauges
- ◆ Ease of use and secure operation by ergonomic design



# GALAXY II

## Copy Router Machine with Triple Slot Drilling

Used for cutting appropriate slots on aluminum and pvc profiles for mounting locks, grips, hinges, latches, and opening channels

- ◆ Copy assembly matching the process
- ◆ Ability to open various channels independently of the copy assembly with profile gauges
- ◆ Pneumatic clamps
- ◆ Triple grip slot drilling system

# GALAXY IV

## Copy Router Machine (3 motors)

Used for lock, handle, hinge and latch slot and channel opening processes without rotating the profile on 3 surfaces of aluminum and pvc profiles

- ◆ Proper copy mechanism for process
- ◆ Ability to open various channels independent from copy mechanism with the help of profile gauges
- ◆ Pneumatic clamps
- ◆ Independently operating motors

# STAR

## Portable Copy Router Machine

Used for cutting appropriate slots on aluminum and plastic profiles for mounting locks, grips, hinges, latches, and opening channels

- ◆ Copy assembly matching the process
- ◆ Ability to open various channels independently of the copy assembly with profile gauges
- ◆ Ease of use and secure operation by ergonomic design

# ORION SERIES \_\_\_\_\_ CORNER WELDING & CLEANING



**PRECISE WELDING**  
WITH THE MOLD SYSTEM WELDING



**SAFETY**  
PROTECTION CABIN



**EFFICIENCY**  
UP TO 350° C WELD CAPABILITY



**USER FRIEND**  
EASY TO USE WITH THE  
BUTTON SYSTEM

The ORION family of welding machines streamline the welding process for four corners of your PVC profiles. Its pneumatic motion ensures smooth operation, while the automatic frame output unit optimizes efficiency.



## ORION I SN

### Automatic Single Head Seamless - Standard PVC Welding Machine

Used for welding processes of pvc profiles at various angles

- ◆ Pneumatic motion
- ◆ Seamless welding and standard welding
- ◆ Welding between 60° and 180
- ◆ One button replacement of welding system
- ◆ Easy Teflon replacement system
- ◆ Automatic process starting and finishing
- ◆ Welding time adjustment and digitally controlled heating
- ◆ Temperature adjustment between 0°C and 350°C with electronic thermostat



 YouTube



## ORION II SN

### Automatic Double Head Seamless / Standard PVC Welding Machine

Used for welding processes of PVC profiles at various angles

- ◆ Pneumatic motion
- ◆ Automatic process starting and finishing
- ◆ Welding without size changes in batch welding processes
- ◆ Welding time adjustment and digitally controlled heating
- ◆ Heat adjustment up to 350°C with digital thermostat
- ◆ Easy Teflon replacement system



 YouTube

## ORION IV

### Automatic Four Head Seamless / Standard Servo Actuated Welding Machine

Used for welding four corners of PVC profiles

- ◆ Pneumatic motion
- ◆ Automatic frame output unit
- ◆ Process programming and large memory
- ◆ Safe working area with safety barrier
- ◆ Welding time adjustment and digitally controlled heating
- ◆ Heat adjustment up to 350°C with digital thermostat
- ◆ Touchscreen control panel
- ◆ Quick and easy to replace welding mold system
- ◆ Batch processing and precision measurement
- ◆ (0.2mm) welding seam
- ◆ Quick and easy to replace hot press Teflon
- ◆ Data transfer over remote network connection
- ◆ Ethernet and USB
- ◆ Alarm and warning sign on screen
- ◆ Uniform heat distribution on plate

# ORBIT SERIES

## CORNER WELDING & CLEANING



The ORBIT family of corner cleaning machines, a powerhouse that seamlessly welds all four corners while simultaneously eliminating post-weld burrs for stunningly finished profiles. Automate your workflow with the intelligent frame output unit, robotic profile transfer system, and fully automatic profile rotation, maximizing efficiency and minimizing manual intervention. Experience unparalleled precision with batch processing that maintains a remarkable 0.0078-inch welding range, ensuring consistent top-notch results. The intuitive touchscreen control panel and profile recognition system empower you to fine-tune settings for diverse profile sizes, while manual control options offer the flexibility to adapt to specific needs. Prioritize operator safety with the integrated safety barrier, while enjoying the peace of mind that comes with real-time communication between the welding and cleaning units for streamlined performance.



**EFFICIENCY**  
FULLY AUTOMATIC SYSTEM



**SAFETY**  
PROTECTION CABIN

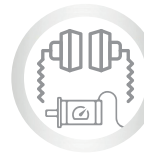

**PRECISE CLEANING**  
HIGH QUALITY STRIPPING KNIVES



**DURABILITY**  
THANKS TO ITS EXTREMELY  
RIGID CHASSIS





## ORBIT III

### Semi-Automatic PVC Corner and Surface Cleaning Machine (Single Cutter Set)

Used for cleaning the burrs created by welding of PVC window rails, doors, frames etc. welded at an angle of 90°

- ◆ Hydro-Pneumatic motion
- ◆ Automatic returning to process starting point.
- ◆ Centering system allowing profiles to correctly fit on a 90° miter
- ◆ Pneumatic clamps



## SIRIUS

### Robotic Automatic PVC Welding and Cleaning Line

- ◆ Pneumatic motion
- ◆ Automatic frame output unit and automatic profile rotation system
- ◆ Batch processing and precision measurement
- ◆ Process programming and large memory
- ◆ Safe working area with safety barrier
- ◆ Welding time adjustment and digitally controlled heating
- ◆ Heat adjustment up to 350°C with digital thermostat
- ◆ 0.2 mm welding range

## ORBIT IV SA

### Automatic PVC Corner and Surface Cleaning Machine (3 Surfaces)

Used for cleaning the burrs created by welding of PVC window rails, doors, frames etc. welded at an angle of 90°

- ◆ Cleaning of bottom, top and external surfaces of the profile by two independent cleaning units
- ◆ Memory capacity for 250 profiles
- ◆ Touchscreen control panel
- ◆ User friendly program entry for corner cleaning
- ◆ Operator adjusted cutting speed and axial speeds



## ORBIT V

### Full Automatic PVC Corner and Surface Cleaning Machine (4 Surfaces)

Used for cleaning the burrs created by welding of PVC window rails, doors, frames and etc. welded at an angle of 90°

- ◆ Cleaning of bottom, top and external surfaces of the profile by two independent cleaning units
- ◆ Memory capacity for 250 profiles
- ◆ Touchscreen control panel
- ◆ User friendly program entry for corner cleaning
- ◆ Operator adjusted cutting speed and axial speeds

# APEX SERIES

## CORNER CRIMPING



The APEX family of corner crimping machines tackles corner crimping for your aluminum profiles with unmatched efficiency and control. Its high-pressure resistant steel plate ensures durability, while the servo-driven automatic positioning guarantees precise crimping every time. Enjoy user-friendly operation with the intuitive touchscreen interface and adapt to various profile sizes with the adjustable clamping system and configurable crimping blades.



**UNIQUE**  
UNMATCHABLE COMPETITION



**SAFETY**  
PROTECTION CABIN



**MAXIMUM PERFORMANCE**  
POWERFUL HYDRAULIC SYSTEM



**PRECISE CRIMPING**  
SERVO CONTROLLED AXIS



## APEX I

### Automatic Hydraulic Aluminum Corner Crimping Machine

Used for corner crimping processes of aluminum profiles.

- ◆ Steel plate with high pressure resistance
- ◆ Hydraulic operating system
- ◆ Easy adjustment of crimping blade distances based on profile.
- ◆ Automatic profile centering with miters
- ◆ Double sided conveyor unit for convenient profile processing
- ◆ Crimping of wide and high profiles



 YouTube

## APEX I A

### Automatic Hydraulic Aluminum Corner Crimping Machine with Rising Miter

- ◆ Steel plate with high pressure resistance
- ◆ Hydraulic operating system
- ◆ Easy adjustment of crimping blade distances based on profile
- ◆ Automatic profile centering with miters
- ◆ Convenient profile rotation by up/down movement of centering miter
- ◆ Double sided conveyor unit for convenient profile processing
- ◆ Crimping of wide and high profiles



 YouTube

## APEX II

### Automatic Hydraulic Double Head Aluminum Corner Crimping Machine

- ◆ Steel plate with high pressure resistance
- ◆ Hydraulic operating system
- ◆ Manual positioning, automatic operating system
- ◆ Adjustable clamping system for wide profiles
- ◆ Easy adjustment of crimping blade distances based on profile
- ◆ Two stage hydraulic pressure setting in assembly
- ◆ Assembly without size changes in batch corner assembling processes

## APEX IV

### Automatic Hydraulic Servo Actuated Four Head Corner Crimping Machine

- ◆ Steel plate with high pressure resistance
- ◆ Automatic positioning with servo system
- ◆ Touchscreen
- ◆ Adjustment of crimping blades based on profile
- ◆ Hydraulic operating system
- ◆ Two stage hydraulic pressure setting in assembly
- ◆ Safe working area with safety barrier



 YouTube

# POLAR SERIES

## END MILLING



**HIGH CAPACITY**  
ADJUSTABLE BLADE HEIGHT



**SAFETY**  
PROTECTION CABIN



**FAST NOTCHING**  
WITH THE 2,2-KW MOTOR



**DURABILITY**  
THANKS TO ITS EXTREMELY  
RIGID CHASSIS

The POLAR family of end milling machines tackle end milling for your aluminum and vinyl profiles with ease, thanks to its efficient hydro-pneumatic motion. Secure your profiles during operation with pneumatic vertical and horizontal clamps and prioritize safety with the cover and its integrated safety sensor.



## POLAR I

### Portable End Milling Machine

Used for end milling processes of aluminum and pvc profiles

- ◆ Vertical and horizontal clamping system
- ◆ Ease of use and secure operation by ergonomic design



 YouTube

## POLAR II

### End Milling Machine

Used for end milling processes of aluminum and pvc profiles

- ◆ Vertical and horizontal clamping system
- ◆ Secure operation by the cover equipped with a safety sensor
- ◆ Profile support conveyor
- ◆ Blade holding station



 YouTube

## POLAR III

### Automatic End Milling Machine

Used for end milling processes of aluminum and pvc profiles

- ◆ Hydro-Pneumatic motion
- ◆ Pneumatic vertical and horizontal clamps
- ◆ Secure operation by the cover equipped with a safety sensor
- ◆ Automatic returning to process starting point
- ◆ End-milling processes at various angles with graded miter
- ◆ Profile support conveyor
- ◆ Blade holding station



 YouTube

## POLAR IV

### Automatic End Milling Machine - Pneumatic Blade Replacement

- ◆ Hydro-Pneumatic motion
- ◆ Pneumatic vertical and horizontal clamps
- ◆ Secure operation by the cover equipped with a safety sensor
- ◆ Automatic returning to process starting point
- ◆ End-milling processes at various angles with graded miter
- ◆ Easy blade replacement
- ◆ Profile support conveyor
- ◆ Blade holding station
- ◆ Blade adapter



 YouTube

## POLAR V

### Automatic End Milling Machine

- ◆ Hydro-Pneumatic motion
- ◆ Hydro-Pneumatic motion
- ◆ Pneumatic vertical and horizontal clamps
- ◆ Secure operation by the cover equipped with a safety sensor
- ◆ End-milling processes at various angles with graded miter
- ◆ Profile support conveyor
- ◆ Blade adapter
- ◆ Blade holding station

# ACCESSORIES / COMPLEMENTARY



USER FRIEND



ERGONOMIC DESIGN

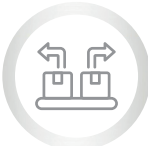

HIGH CARRY CAPACITY



VERSATILITY

This versatile solution combines a window and door assembly station with an adaptable profile conveyor, offering ergonomic work surfaces, integrated utilities, precise measurement, and scalable length for efficient and seamless production workflows.

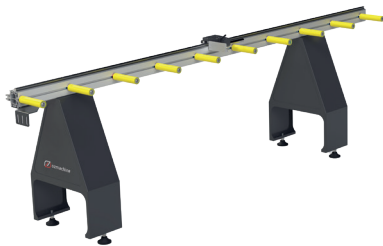

## WT II

### Assembly Table

Used for assembling window and door profiles

- ◆ Ability to work with large sized window and door frames with sliding and extendible working surfaces
- ◆ Ability to work ergonomically with the bevel adjustable between 0° and 75°
- ◆ Power plug and air outlet sockets
- ◆ Cord system preventing material scratches

## K 3000 / K 6000

### Conveyor - 3 m / 6 m

Used for conveying aluminum, pvc, and metal profiles

- ◆ Measurement gauge and ruler
- ◆ Practical height adjustment based on machine
- ◆ Optional extension by addition of 3 m conveyor

## COMET M

### Manual Conveyor

Used for conveying aluminum, PVC and metal profiles

- ◆ Manual positioning
- ◆ Measuring capacity up to 3 meters
- ◆ Easy installation on machines

## COMET MD

### Manual Conveyor with Digital Measurement Display

Used for conveying aluminum, PVC, and metal profiles

- ◆ Positioning with manual rotary arm
- ◆ Digital measurement indicator
- ◆ Measuring capacity up to 3 meters
- ◆ Easy installation on machines

## COMET DD

### Digital Conveyor with Profile Gauge

Used for conveying aluminum, PVC and metal profiles

- ◆ Measuring capacity up to 3 meters
- ◆ Easy installation on machines
- ◆ Touchscreen
- ◆ Automatic positioning

# ACCESSORIES / COMPLEMENTARY



USER FRIEND



ERGONOMIC  
DESIGN



HIGH CARRY  
CAPACITY



VERSATILITY

This system facilitates efficient and effortless transportation of profiles, minimizing manual handling and optimizing workflow. It offers space-saving benefits by keeping profiles organized and readily accessible.



## S I D / S I I D

### Stant (M) / Stant (L)

- ◆ Gasket Knockdown Stand

## VELA

### Dust Vacuuming System

- Used for vacuuming dust in wooden, aluminum, and composite material processing
- ◆ 700 m<sup>3</sup>/h vacuum power

## CART V

### Vertical Profile Transport Trolley

- ◆ Vertical Profile Transport Trolley

## CART W

### Door and Window Trolley

- ◆ Door and Window Trolley.

## CART C

### Window Trolley

- ◆ Window Trolley

## CART H

### Horizontal Profile Transport Trolley

- ◆ Horizontal Profile Transport Trolley

## CART G

### Gasket Transport Trolley

- ◆ Gasket Transport Trolley

## PLANET

### Hinge Slot Milling Machine

- Used for opening hinge slots on wooden materials.
- ◆ Robust spring system
- ◆ User friendly measurement ruler
- ◆ Ease of use and secure operation by ergonomic design.



 YouTube

# SOLUTION PARTNERS





by  özçelik

[www.oz-machine.com](http://www.oz-machine.com)

Our company reserves the right to revise the specifications, design and prices of the products without notice, and is not bound by mistakes that may derive from the design or printing of this catalogue.



by  özçelik



## ÖZÇELİK MAKİNA SAN. VE TİC. A.Ş.

Anadolu Mh. Kanuni Cd. No.8 34956 Orhanlı, Tuzla, İstanbul / Turkey  
T: +90 216 304 20 10 | F: +90 216 304 19 88  
[www.oz-machine.com](http://www.oz-machine.com) | [info@oz-machine.com](mailto:info@oz-machine.com) / [info@ozcelik.com](mailto:info@ozcelik.com)

Information in this catalogue may be subject to change without notice. Özçelik Makina San ve Tic AŞ is not liable for errors or inaccuracies in the provided information. Trademarks, logos, and brand names used in this catalogue are the property of Özçelik Makina San ve Tic AŞ. Unauthorized use is strictly prohibited.